

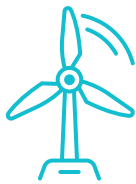

Contact us:
01189 324600
sales@bt2000.co.uk

SUPERCAPACITOR



Leading manufacturer of Supercapacitor and Fuel Cell Component



Supercapacitor PRODUCT APPLICATIONS AREA



AUTOMOTIVE & AFTER-MARKET

- Navigation and Dash Camera
- Memory Back Up
- Car Subwoofer
- Compensate peak power
- Vehicle tracking and security
- Fail Safe applications, E-Call & E-Latch

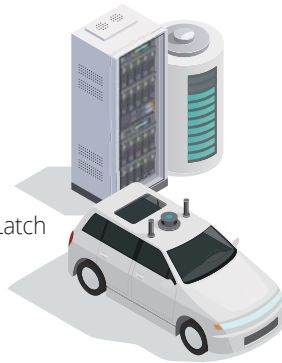

SENSOR NETWORKS, COMMUNICATIONS

- Long Term Back Up
- Pulse management
- 3.8 V Lithium Capacitor



UNINTERRUPTIBLE POWER SUPPLY(UPS), DYNAMIC VOLTAGE RESTORER(DVR)

- Responds to momentary blackouts
- Compensate peak power
- Engine cranking

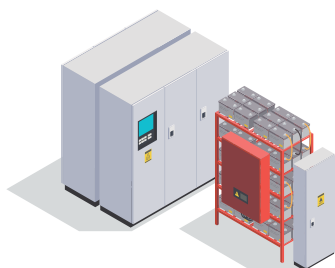

SMART METERS / NETWORK EQUIPMENT

- Long life & Near maintenance free
- Wider operating temperature : -40 °C to +85 °C





MEMORY BACK UP

- RAID, SSD, NVDIMM, DRAM to NAND Flash, Cache protection power backup
- Applied spec. : 3.0 V (1 F ~ 100 F)
- Circuit configuration based on cache density and power requirements

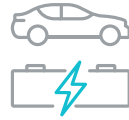
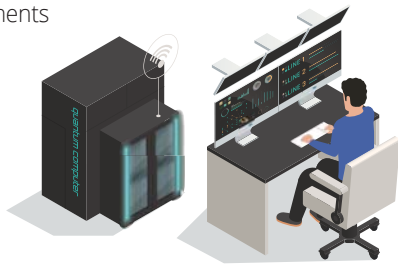

REGENERATIVE ENERGY STORAGE DEVICE

- Hybrid electric cars, suitable for elevators or railway vehicles
- Reduce energy cost and CO₂ emission

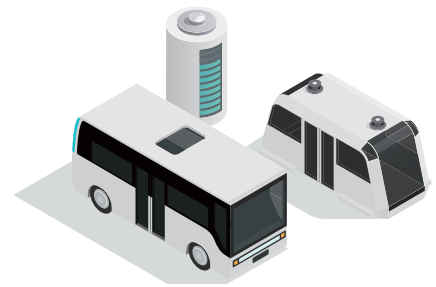

WIND TURBINE

- Pitch control
- Compensate peak power
- Long - Lasting & Near maintenance free



OTHER APPLICATION

- Medical & Dental equipment
- Actuators and Locking systems
- Building controls, Drones and Toys
- Robotics AGV Fault Indicators

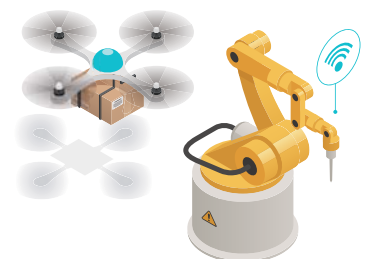



Supercapacitor INTRODUCTION

Environment-friendly Energy Storage Device

EDLC (Electric Double Layer Capacitor also known as Super Capacitor or Ultra Capacitor), are environment friendly energy storage devices with low energy density and high power density when compared to Battery technology. The advantages of EDLC are high current, fast charge and discharge, long cycle life (500,000 + cycles) and long lifetime with wide temperature ranges (-40 °C ~ +85 °C) RoHS, REACH & WEEE compliant safe for transportation.

VPC ranges are the new high density environment friendly Lithium Capacitor offer high energy, low ESR and ultra low Leakage Current in small packages.

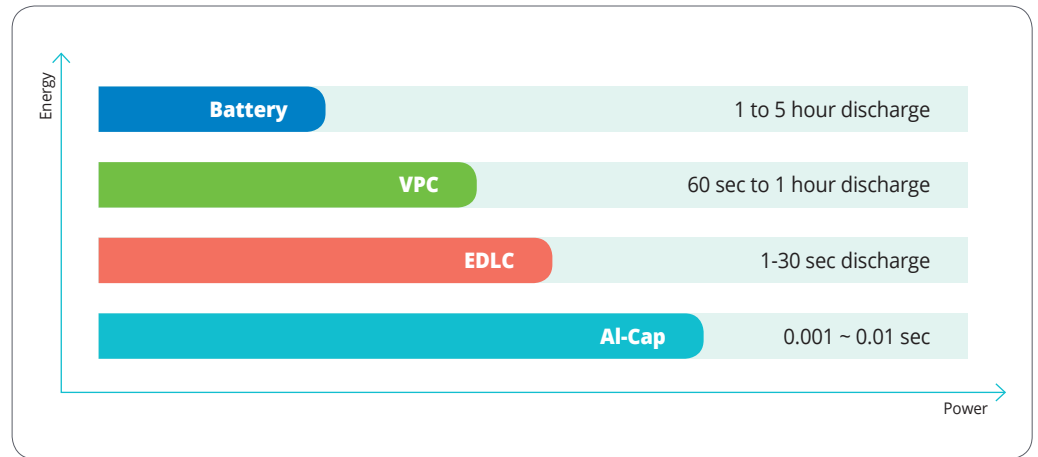

VINATech Supercapacitor Series

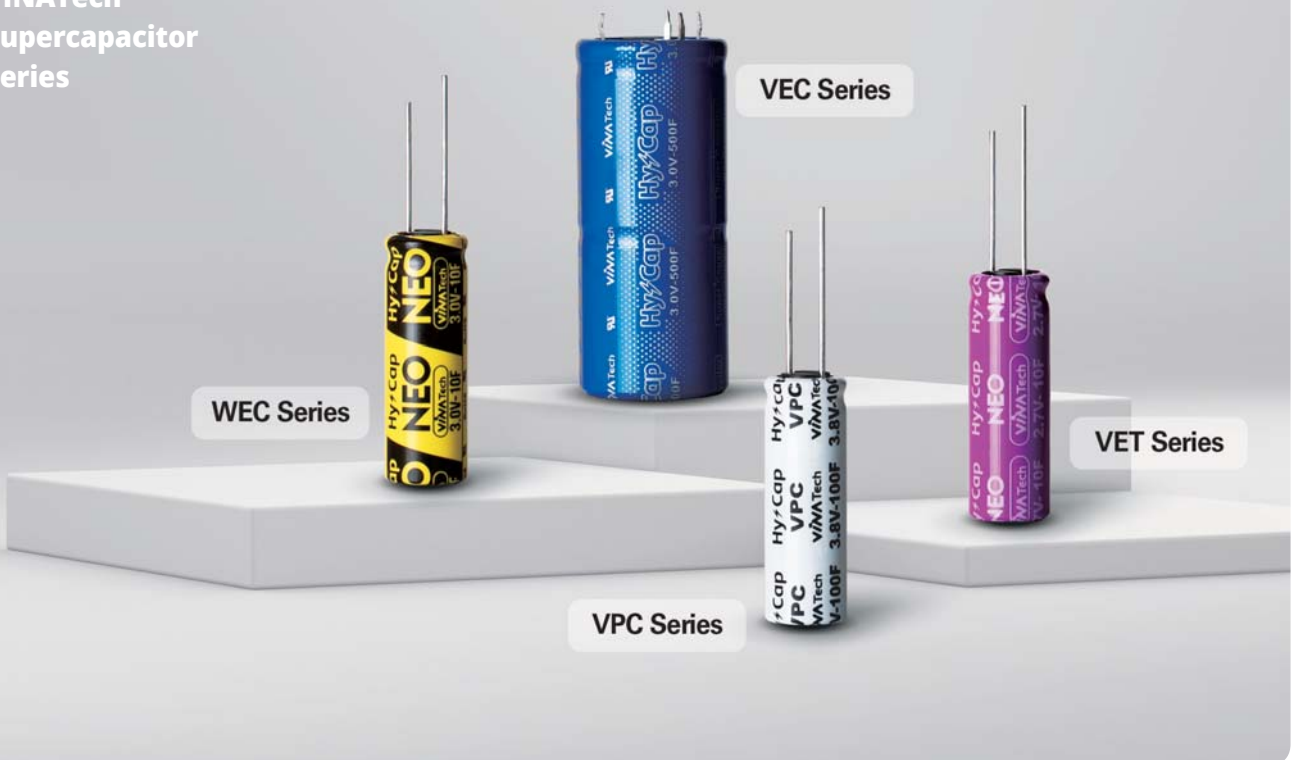



Supercapacitor CHARACTERISTICS

Product Series	EDLC (VEC/WEC)	EDLC (VET)	VPC (VEL)
Voltage	Rated Voltage 3.0 V	Rated Voltage 2.7 V	Operating Voltage Range 2.5 V to 3.8 V
Operating Temp.	-40 °C ~ +65 °C (+85 °C when de-rated)	-40°C ~ +85 °C	-25 °C ~ +85 °C (-40 ~ 85 °C in Li/SOCL ₂ battery system)
High Temp. Load life	1000 hours / V _R loaded under 65 °C	1000 hours / V _R loaded under 85 °C	1000 hours / 3.8 V loaded under 70 °C
Capacitance	≤ 30 % of initial value		≤ 30 % of initial value
ESR	≤ 2 times of specified value	≤ 3 times of specified value	≤ 2 times of specified value
85 °C Voltage	De-rated voltage Max 2.4 V	Rated Voltage 2.7 V	Operating Voltage Range 2.5 V to 3.5 V
Cycle	500,000		50,000
Shelf life storage	3 years from manufacturing date No electrical charge & Temp. below 25 °C (ΔC : ≤ 10% of initial value / ΔESR : ≤ 50 % of specified value)		2 years from manufacturing date Temp. below 45 °C Recommend every 6 month to charge V _R from manufacturing date (C ≤ 10 % of initial value / ESR ≤ 50 % of specified value)

Measurement of Capacitance & ESR

Capacitance (F)

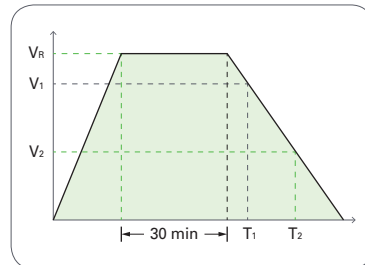

$$C(F) = I \times \frac{(T_2 - T_1)}{(V_1 - V_2)}$$

V _R	Rated Voltage
V ₂	0.8 V _R
V ₁	0.4 V _R
I	Discharge Current (1 mA per Farad)

DC ESR(Rd) is calculated by voltage drop (ΔV) which is measured by the period of time from discharge start to 10 milli - seconds later.

Equivalent Series Resistance (ESR)

AC ESR is measured by 4 - probe impedance analyzer.

* Condition : Potentiostat mode, AC amplitude : 5 mV, Frequency : 1 kHz

VPC Measurement of Capacitance

C : Discharge capacitance (F)

I : Discharge Current (A)

T₁ : time (s) from discharge start to reach U_R

T₂ : time (s) from discharge start to reach U_L

T_{cy} : Constant Voltage charging time: 30min)

U_L : Rated lower limit voltage (V), U₂, at equation

U_R : Rated voltage (V), U₁ at equation

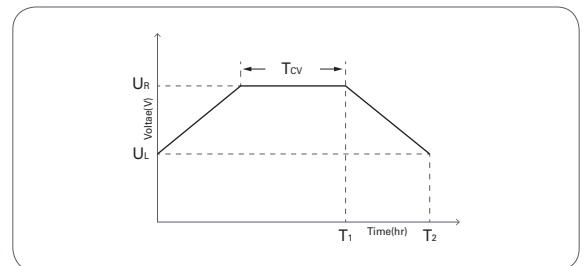

* Module specification for 2 series cells has identical characteristics to above items.

* All test data in this catalogue follow IEC guidelines and VINATech use 25c for all tests unless otherwise stated.

* Visit our Web site for our new Capacitor Calculator.

* Please contact us hycap@vina.co.kr if you need detailed datasheets and customization.



Supercapacitor

SINGLE CELL / LEAD TERMINAL TYPE

VINATech R&D team has developed the EDLC technologies in both 2.7 V and 3.0 V radial series to overcome the increasing challenges being faced by customers when finished products are installed in extreme conditions in areas of high temperature and high humidity. The challenging conditions are over and above recommended specifications for standard EDLC.

Features

- High Power Density
- Over 500,000 cycle life (semi-permanent)
- RoHS/WEEE/REACH compliant
- Long - term reliability improved for extreme condition
- Short term peak power assist application



Drawing

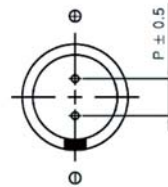
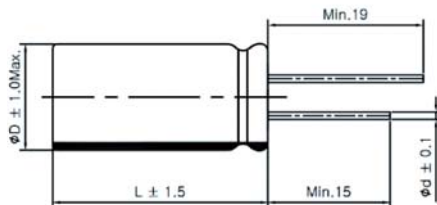

D (Ø)	8	10	13	16	18
d (Ø)	0.6			0.8	
P (mm)	3.5	5.0		7.5	

Part Number	Rated Voltage	Capacitance (F)	ESR (mΩ)		Max. Current (A)	Leakage Current (mA, 72 hr)		Size (mm) D × L	Weight (g)	Volume (ml)
	(V _R)		AC (1 kHz)	DC		(@ 2.7 V)	(@ 3.0 V)			
WEC3R0105QG	3.0	1	145	215	1.2	0.002	0.003	08 × 13	1.1	0.7
WEC3R0155QG		1.5	115	175	1.5	0.003	0.005	08 × 20	1.4	1.0
WEC3R0335QG		3.3	75	125	3.5	0.007	0.010	08 × 20	1.5	1.0
WEC3R0505QD		5	50	85	5.0	0.010	0.015	08 × 25	1.8	1.3
WEC3R0505QG		5	80	120	4.5	0.010	0.015	10 × 20	2.1	1.6
WEC3R0705QD		7	45	75	6.5	0.014	0.021	08 × 30	2.2	1.5
WEC3R0705QG		7	80	135	5.0	0.014	0.021	10 × 20	2.2	1.6
WEC3R0106QA		10	45	75	8.5	0.020	0.030	10 × 25	2.6	2.0
WEC3R0106QG		10	30	45	10.0	0.020	0.030	10 × 30	3.2	2.4
WEC3R0106QD		10	50	75	8.5	0.020	0.030	13 × 20	3.4	2.7
WEC3R0156QG		15	37	55	12.0	0.030	0.045	13 × 25	4.5	3.3
WEC3R0186QC		18	30	50	14.0	0.036	0.054	13 × 25	4.8	3.3
WEC3R0256QG		25	20	30	21.0	0.050	0.075	16 × 25	7.2	5.0
WEC3R0506QG		50	13	20	37.0	0.100	0.150	18 × 40	12.5	10.2
WEC3R0606QG		60	13	20	40.0	0.120	0.180	18 × 40	13.5	10.2
WEC3R0107QD		100	12	20	50.0	0.200	0.300	18 × 59	17.5	15.0

* Max. Current : 1 sec. discharge to 1/2 V_R
 * Connecting a module more than 2 series, please fully discharge over 1 hour first, then assemble right after within 1 hour
 * N.B. VEC lead terminal series is not for New Designs
 * Taping versions available for volume orders 8 mm, 10 mm & 13 mm diameter products Also pre bending available
 * For 2.7 V and 5.4 V VEC EDLC, not recommended for new design



Supercapacitor MODULE IN 2 SERIES

Features

- High Power Density
- Over 500,000 cycle life (Semi-permanent)
- 2 units serially connected to products
- RoHS/WEEE/REACH compliant
- Long term reliability improved for extreme condition



Drawing

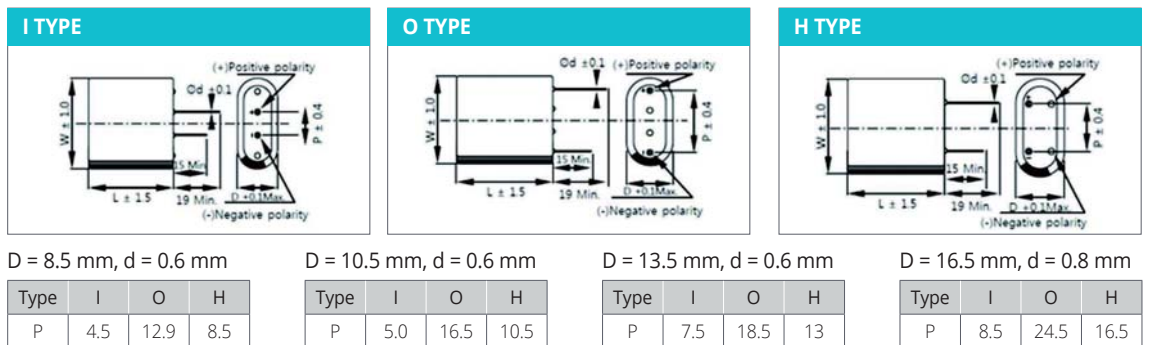

Item	Characteristic	
Product series	EDLC 2 Serial Module	
Rated Voltage (V_R)	6.0 V	
Operating Temperature	-40°C ~ +65 °C (85 °C when de-rated)	
Capacitance Tolerance	-10 % ~ +30 %	
High Temp. Load Life	After 1,000 hours at V_R loaded under +65 °C, capacitor meet the following criteria.	
	Capacitance Change	≤ 30 % of initial value
	ESR	≤ 2 times of specified value
Cycle Life Characteristics	Cycle	Over 500,000
	ΔC	≤ 30 % of initial value
	ESR	≤ 2 times of specified value
	Method	Cycle of Charge/discharge from V_R to $1/2 V_R$
Shelf life	3 years No Electrical Charge & Temp. below 25 °C (ΔC : ≤ 10 % of initial value / ΔESR : ≤ 50 % of specified value)	

Part Number	Rated Voltage	Capacitance	ESR (m Ω)		Max. Current	Leakage Current (mA, 72 hr)		Size (mm)	Weight (g)	Volume (ml)
	(V_R)		(F)	AC (1 kHz)		DC	(@ 5.4 V)			
WEC6R0504QG	6.0	0.5	295	435	1.2	0.002	0.003	8.5 x 17 x 15.5	2.5	2.2
WEC6R0155QG		1.5	155	255	3.5	0.007	0.010	8.5 x 17 x 22	3.3	2.8
WEC6R0255QG		2.5	165	245	4.5	0.010	0.015	10.5 x 21 x 22.5	4.7	4.4
WEC6R0355QG		3.5	165	275	5.5	0.014	0.021	10.5 x 21 x 22.5	4.7	4.4
WEC6R0505QA		5.0	95	155	8.5	0.020	0.030	10.5 x 21 x 27	6.6	6.3
WEC6R0505QG		5.0	65	95	10.0	0.020	0.030	10.5 x 21 x 32	6.6	7.1
WEC6R0755QG		7.5	79	115	12.0	0.030	0.045	13 x 26 x 28	9.6	9.5
WEC6R0126QG		12.5	45	65	21.0	0.050	0.075	16.5 x 32.5 x 28	17.2	17.7

* Max Current : 1sec. discharge to $1/2 V_R$
 * When connecting more than 2 series, please fully discharge over 1 hour first, then assemble right after within 1 hour
 * For 5.4 V or VEC series, please contact the sales office (VEC and 5.4 V is not recommended for new design)
 * For 3 Series (9 V) modules, contact the sales office



Supercapacitor

SINGLE CELL / SNAP-IN TYPE

Features

- High Power Density Low ESR
- Over 500,000 cycle life (Semi - permanent)
- RoHS/WEEE/REACH compliant



Drawing

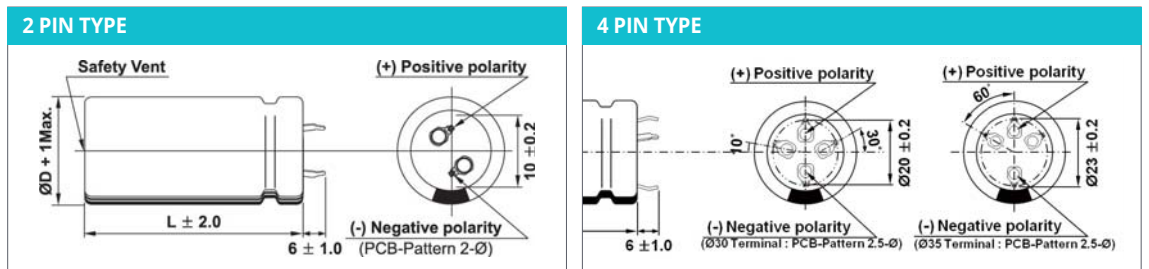

D (Ø)	22	25	35		
P (mm)	45	70	62	72	82

Item	Characteristic	
Product series	EDLC	
Rated Voltage (V_R)	3.0 V	
Operating Temperature	-40 °C ~ +65 °C (85 °C when de - rated)	
Capacitance Tolerance	-10 % ~ +30 %	
High Temp. Load Life	After 1,000 hours at V_R loaded under + 65 °C, capacitor meet the following criteria.	
	Capacitance Change	≤ 30 % of initial value
	ESR	≤ 2 times of specified value
Cycle Life Characteristics	Cycle	Over 500,000
	ΔC	≤ 30 % of initial value
	ESR	≤ 2 times of specified value
	Method	Cycle of Charge/discharge from V_R to 1/2 V_R
Shelf life	3 years No Electrical Charge & Temp. below 25 °C (ΔC : ≤ 10 % of initial value / ΔESR : ≤ 50 % of specified value)	

Part Number	Rated Voltage	Capacitance	ESR (mΩ)		Max. Current	Leakage Current (mA, 72 hr)	Size (mm)	Weight (g)	Volume (ml)
	(V_R)		(F)	AC (1 kHz)			DC		
VEC3R0107QG	3.0	100	6.0	9.0	78	0.300	22 x 45	20.0	17.1
VEC3R0227QG		220	5.0	7.5	125	0.660	25 x 70	38.0	34.3
VEC3R0367QG		360	3.0	3.2	250	1.080	35 x 62	70.0	59.6
VEC3R0387QG		380	3.0	3.2	257	1.140	35 x 62	70.0	59.6
VEC3R0407QG		400	3.0	3.2	263	1.200	35 x 72	80.0	69.2
VEC3R0507QG		500	3.0	3.2	288	1.500	35 x 82	96.0	78.9

* Max. Current : 1 sec. discharge to 1/2 V_R
 * VEC 2.7V Snap-in type is not recommended for new design



Supercapacitor

VET TO COMBAT EXTREME CONDITIONS

Due to the characteristics of electrolytes, there were many difficulties and limitations in improving the high-temperature characteristics of supercapacitors in the past. However now the R&D Team at VINATech have developed a new supercapacitor solution of NEO VET Series which will be particularly ideal for all IoT and AMI applications.

Features

- VET series of +85 °C Single cell 2.7 V Supercapacitor
- Over 500,000 cycle life (semi-permanent)
- RoHS compliant
- High Power Density
- Short - term Peak Power assist applications
- Long - term reliability improved at high temperature 85 °C and humidity of 85 % RH



Drawing

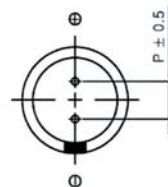
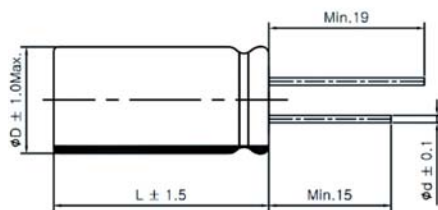

D (Ø)	8	10	13		
L (mm)	20	20	30	40	25
d (Ø)	0.7				
P (mm)	3.5	5.0			

Item	Characteristic	
Rated Voltage (V _R)	2.7 V	
Operating Temperature	-40 °C ~ +85 °C	
Capacitance Tolerance	-10 % ~ +30 %	
High Temp. High Humidity Load Life	After 1,000 hours at V _R loaded under +85 °C, 85 % RH Humidity, capacitor meet the following criteria.	
	Capacitance Change	≤ 30 % of initial value
	ESR	≤ 3 times of specified value
Cycle Life Characteristics	Cycle	Over 500,000
	ΔC	≤ 30 % of initial value
	ESR	≤ 3 times of specified value
	Method	Cycle of Charge/discharge from V _R to 1/2 V _R
Shelf life	3 years No Electrical Charge & Temp. below 25 °C (ΔC : ≤ 10 % of initial value / ΔESR : ≤ 50 % of specified value)	

* Max. Current : 1 sec. discharge to 1/2V_R

* Note : The products are tested based on the test conditions and methods defined

Part Number	Rated Voltage (V _R)	Rated Capacitance (F)	ESRAC (mΩ)	ESRDC (mΩ)	Max Current (A)	Leakage Current (mA)	Size (mm)	Weight (g)
	Surge Voltage (3.0 V)	@ 25 °C	@ 25 °C 1 kHz	@ 25 °C 10 msec	@ 25 °C	@ 25 °C	D × L	
VET2R7335QG	2.7	3.3	140	210	2.5	0.010	08 × 20	1.5
VET2R7505QG		5	90	135	4	0.015	10 × 20	2.2
VET2R7106QG		10	50	75	7.5	0.030	10 × 30	3.2
VET2R7156QD		15	40	60	10.5	0.040	10 × 40	4.3
VET2R7156QG		15	40	60	10.5	0.040	13 × 25	4.5

* For purchasing modules, please contact hycap@vina.co.kr.



Supercapacitor VPC VINA PULSE CAPACITOR

New powerful VPC series offer High Energy Density, ultra low Leakage Current, low ESR and high energy from a new miniaturised Lithium Capacitor development. VINATech has responded to market requests with 30F capacitance in 08 x 20 can, 100F, 150F and 250F family products. Ideally suited to supporting Battery powered products and IoT applications.

Features

- Ultra Low Self Discharge
- High Operating Voltage
- High Energy Density
- High Capacitance
- Wide Operating Temperature Range



Drawing

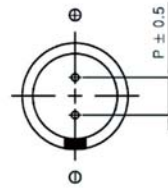
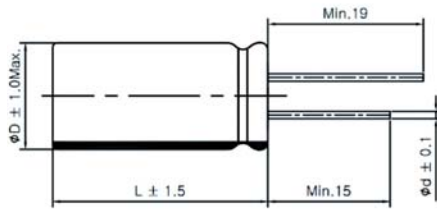

D (Ø)	8	10	13	13
L (mm)	20	30	25	35
d (Ø)	0.8			
P (mm)	3.5	5.0		

Item	Spec. value	Test methods
Operating Voltage Range	2.5 V to 3.8 V (2.5 V to 3.5 V @ 85 °C)	
Operating Temp. Range	-25 °C ~ 85 °C (-40 °C ~ 85 °C @ in Li/SOCL ₂ battery system)	
Load Life @ 70 °C	Capacitance : ≤ 30 % of initial value ESR : ≤ 2 times of specified value Appearance : No abnormality	- Temperature : 70 \pm 2 °C, 85 \pm 2 °C - Time : 1,000 hours - Voltage : 3.8 V, 3.5 V and measure the floating charge characteristics after returning to normal temperature and humidity.
Load Life @ 85 °C		
Heat cycle characteristics		- Temperature : 85 \pm 2 °C, -40 \pm 2 °C - Duration : 30 min - Cycle Numbers : 100 cycles
Cycle Life		- Temperature : 25 \pm 2 °C - Cycle Number : 50,000 - Discharge Current : 20 C - rate - Cut-off Voltage : 2.5 V (DOD 100 %)
Low Temperature characteristics	Capacitance : ≤ 50 % of initial value ESR : Less than 20 times of specified spec.	The specification shall be met lower category temperature range of -25 °C

#1 Reference IEC62813 4.2
#2 1sec. Discharge to 3.2 V

Part Number	Rated Voltage (V _R)	Rated Capacitance (F)	ESRAC (mΩ)	ESRDC (mΩ)	Leakage Current (μA)	Self Discharge (V)	Rated Current (A)	Pulse Current (A)	Weight (g)	Energy Density (Wh/kg)	Capacity (Ah/kg)
	Surge Voltage (4.0 V)	@ 25 °C #1	@ 25 °C 1 kHz	@ 25 °C 100 msec	@ 25 °C 72 hr	@ 25 °C #1	@ 25 °C	@ 25 °C #2			
VEL08203R8306G	3.8	30	350	700	1	-3 %	0.15	0.5	1.9	17.961	5.702
VEL10303R8107G		100	100	200	2		0.4	2.0	4.2	27.083	8.598
VEL13253R8157G		150	70	140	3		0.5	3.0	6.2	27.520	8.737
VEL13353R8257G		250	50	100	5		0.75	5.0	8.2	34.680	11.009

* Energy Density (Wh) : $[0.5 \times C \times \{(V_{\text{rated}})^2 - (V_{\text{min}})^2\}] / 3600$
* Capacity (Ah) : $[C \times (V_{\text{rated}} - V_{\text{min}})] / 3600$



Supercapacitor USER GUIDANCE

01

Do not take the product apart or damage at random. Follow guidelines for product installation (Soldering, pin formation etc.) Warranty will not be provided if damage resulting from a failure to follow installation guidelines.

02

Polarity

+ This is a polarised product (+positive and -negative poles) so it must be used accordingly. The negative pole is clearly marked on the product sleeve.

03

Overvoltage and overcurrent

- + It is recommended that the product should be used below the rated voltage. When used over the rated voltage, it could lead to vent expansion and failure, the useful life span will be shortened.
- + In case of connecting more than 2 units for modules, we recommend lowering the operating voltage per cell by a minimum of 10 % from the rated voltage to ensure safer voltage balancing (e.g. 2.43 V per unit in case of 2.7 V series).
- + It is recommended that the product should be applied below the maximum current. When used above the maximum current, it will lead to can expansion and failure or its life span will be shortened.

04

Working conditions and storage

- + Working life of this product will be shortened by the working environmental conditions, such as temperature, humidity and air pressure among others.
- + Do keep the product within environmental conditions that are recommended in this document. Check with the sales office.
- + Do not expose the product to over 75 % relative humidity. When exposed for a long time, its life can be shortened or it can cause malfunction.
- + Do not use or keep the product in the temperature range that is higher than recommended in this document. Its life will be shortened or it can cause malfunction.
- + Do not use or keep the product in highly corrosive atmospheres that is composed of substances (for example, the environment that is exposed to halogen substances, such as Cl, F, or halogen compounds, nitrogen substances or nitrogen compounds, sulphur substances or sulphur compounds, hexavalent chrome, arsenic, and, etc.).

EDLC Lead Terminal Bending Process

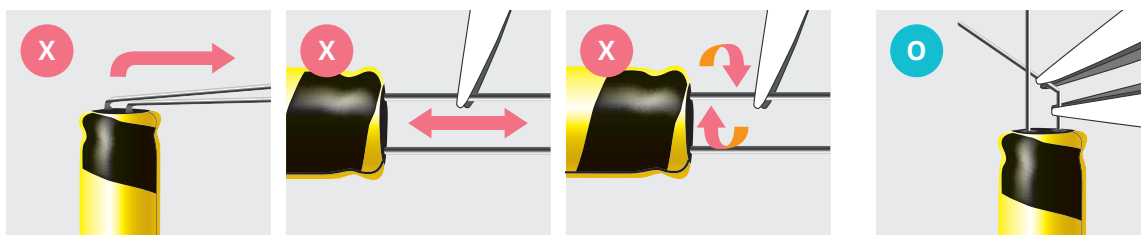

VPC Handling Instructions

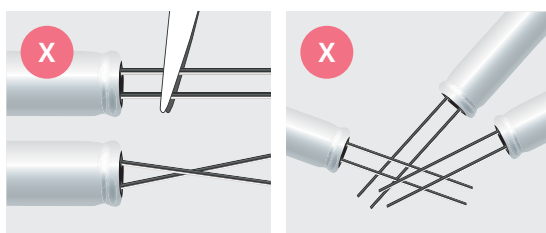

* Product head and fire may occur due to incorrect product storage, product measurement and processing.



Supercapacitor MODULE CUSTOMIZED SERIES

Features

- Ultra - low internal resistance
- High - power and reliable performance
- Over 500,000 duty cycles
- Compact & fully enclosed splash proof design

Applications

- Automotive
- AGV/Robotics
- Consumer electronics
- Renewable energy system
- Short term UPS & Telecommunications
- Wind turbine pitch control

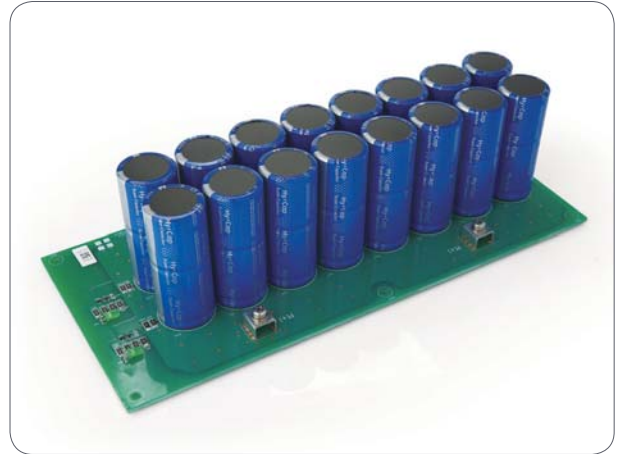

Item	Characteristic	
Product series	EDLC Customized Series Module	
Operating Temperature	-40 °C ~ +65 °C (85 °C when de - rated)	
Capacitance Tolerance	-10 % ~ +30 %	
High Temp. Load Life	After 1,000 hours at V_R loaded under +65 °C, capacitor meet the following criteria.	
	Capacitance Change	≤ 30 % of initial value
	ESR	≤ 2 times of specified value
Cycle Life Characteristics	Cycle	Over 500,000
	ΔC	≤ 30 % of initial value
	ESR	≤ 2 times of specified value
	Method	Cycle of Charge/discharge from V_R to $1/2 V_R$
Shelf life	3 years No Electrical Charge & Temp. below 25 °C (ΔC : ≤ 10 % of initial value / ΔESR : ≤ 50 % of specified value)	

Part Number	Rated voltage (V)	Capacitance (F)	DCESR (mΩ)	Cell Structure	Size(mm) (W x L x H)	Weight (kg)	Energy density (Wh/kg)	Power density (W/kg)
VEM30R0366QG	30	36	55	3.0V - 360F 10S	122 x 150 x 70	0.85	5.3	2,310
VEM30R0106QG	30	10	95	3.0V - 100F 10S	160 x 60 x 50	0.35	3.6	3,248
VEM60R0505QG	60	5	180	3.0V - 100F 20S	146 x 104 x 70	0.45	5.6	5,333
VEM18R0606QG	18	60	20	3.0V - 360F 6S	37 x 233 x 70	0.67	3.2	2,293
VEM144R0755QG	144	7.5	165	3.0V - 360F 48S	315 x 340 x 70	4	5.4	3,770
VEM18R0127QG	18	120	19	3.0V - 360F 6S2P	270 x 100 x 70	1	5.4	2,046
VEM90R0166QG	90	16.6	145	3.0V - 500F 30S	400 x 200 x 90	3.5	5.3	1,915



Supercapacitor

UNDER DEVELOPMENT (Samples Available)

Single Cell / Lead Terminal Type

Part Number	Rated Voltage (V _R)	Capacitance (F)	Size (mm) D X L
WEC3R0105QD	3.0	1	06 x 12
VEC3R0205QD	3.0	2	05 x 25
VEP3R0106QG (Low ESR)	3.0	10	10 x 30

Single Cell / Snap-In Type

Part Number	Rated Voltage (V _R)	Capacitance (F)	Size (mm) D X L
VEC3R0287QG	3.0	280	30 x 60
VEC3R0487QG	3.0	480	35 x 71

VPC (Vina Pulse Capacitor)

Part Number	Rated Voltage (V _R)	Capacitance (F)	Size (mm) D X L
VEL13203R8107D	3.8	100	13 x 20
VEL10403R8157D	3.8	150	10 x 40
VEL13463R8357G	3.8	350	13 x 46
VEL18403R8607G	3.8	600	18 x 40
VEL18653R8128G	3.8	1200	18 x 65
VEL35623R8358G	3.8	3500	35 x 62

VEL35623R8358G Samples Available date : 1Q. 2022

Module Customized Series

Part Number	Rated Voltage (V _R)	Capacitance (F)	DCESR (mΩ)	Cell Structure	Weight (kg)	Energy density (Wh/kg)	Power density (W/kg)
VEM180R0605QG	180	6	280	3.0V - 360F 60S	5	5.4	2,777

Samples Available date : Jan. 2022

LIC Pouch Type

Part Number	Rated Voltage (V _R)	Capacitance (F)	Size (mm) A X C
Not fixed	3.8	3,200	153 x 122

Samples Available date : Mar. 2022



Supercapacitor DEVELOPMENT ROADMAP

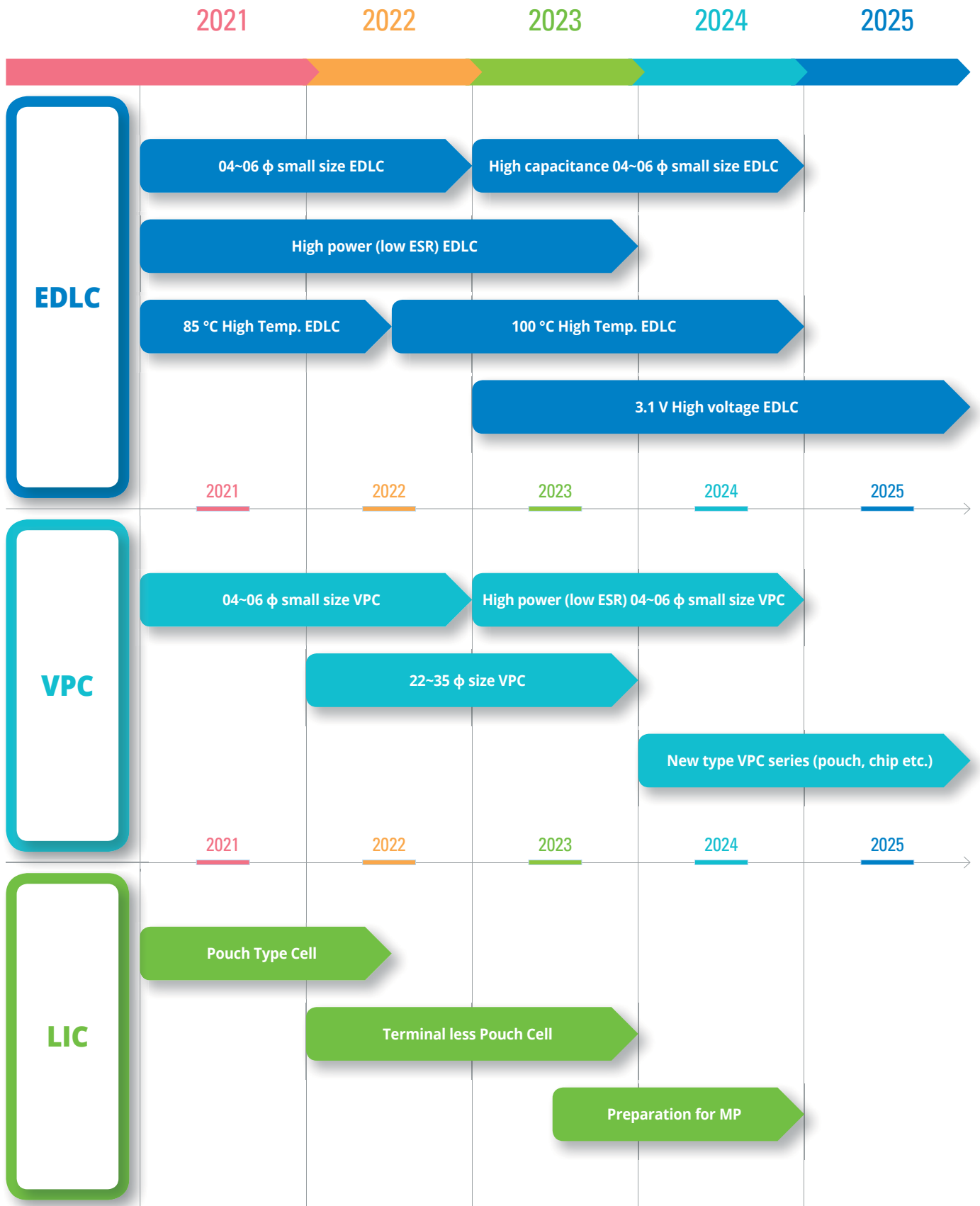

ABOUT VINATech



Leading manufacturer of Supercapacitor and Fuel Cell Component



ABOUT VINATech

Leading manufacturer of Supercapacitor
Comprehensive producer of Fuel cell Component

VINATech endeavour to fulfil the happiness of our customers, employees and shareholders as well as our society, by offering environment friendly products.

VINATech is the leading Supercapacitor manufacturer and provides the energy saving device including Supercapacitor and Lithium Capacitor. VINATech provides Fuel Cell Component including Carbon support, Pt/C Catalyst, and Membrane Electrode Assembly (MEA) comprehensively with securing Carbon technology which VINATech have researched and developed for environment friendly future growth. It is applied as many as areas from Social Infrastructure for building Smart City to hydrogen fuel cell related area.

VINATech HISTORY

1999
START UP



1999 | Company Founded

2003 | Supercapacitor R&D started

2004 | Registered R&D center

2004 | Production of Supercapacitor started

2005
BUILD UP



2005 | Venture Company Grand Award

2006 | Selected as Promising Small Business Company

2008 | Best HRD Certification

2010 | 3V Supercapacitor Development

DISTRIBUTION & SUPERCAPACITOR BIZ.



R&D · MANUFACTURING TECHNOLOGY IMPROVEMENT



VINATech PROFILE

Company	VINATech Co., LTD.
Foundation	July 1999
Head office & Factory	15, Unam-ro, Deokjin-gu, Jeonju-si, Jeollabuk-do, Korea (postal code 54853)
Overseas Factory	Ha Lieu Hamlet, Phuong Lieu Commune, Que Vo District, Bac Ninh Province 16800
Main Business	<ul style="list-style-type: none"> • Supercapacitor • Fuel Cell Component

2011 JUMP UP

- 2011** | Relocate Headquarters (Gunpo → Jeonju)
- 2012** | Selected Global Small & Strong Business
- 2012** | Grand Prize Small Business IP Manager
- 2013** | KONEX Stock Market IPO
- 2013** | Start Carbon Materials Business (Fuel Cell, Environment Filter)
- 2014** | Awarded for IP - R&D from Korea IP Office
- 2016** | Selected 'Global Small Giant Company' from Industry Ministry

ENERGY STORAGE DEVICE EXPERT COMPANY



2017 GROW UP

- 2017** | 'VINATech VINA' established in Bac Ninh, Vietnam
- 2018** | Vietnam Factory Start operation
- 2018** | R&D Center built in HQ
- 2019** | Leading SME Award by Government of South Korea
- 2020** | KOSDAQ Stock Market IPO
- 2020** | Acquired Acecreation (Bipolar Plate)
- 2021** | Wanju factory (55,000 m²) Groundbreaking Ceremony

ENERGY STORAGE DEVICE LEADING COMPANY



VINA MISSION

Through the happiness of our members, we provide eco-friendly products and contribute to the building of a harmonious society



HEADQUARTER (JEONJU FACTORY / R&D LAB)

15, Unam-ro, Deokjin-gu, Jeonju-si, Jeollabuk-do, Korea
(postal code 54853)
Tel | +82-63-715-3020

SALES OFFICE

AcroTower, B-607, Simin-daero 230, Dongan-gu,
Anyang-si, Gyeonggi-do, South Korea (postal code 14067)
Tel | +82-31-448-3066 E-mail | hycap@vina.co.kr

